

*Advanced flexible manufacturing system*

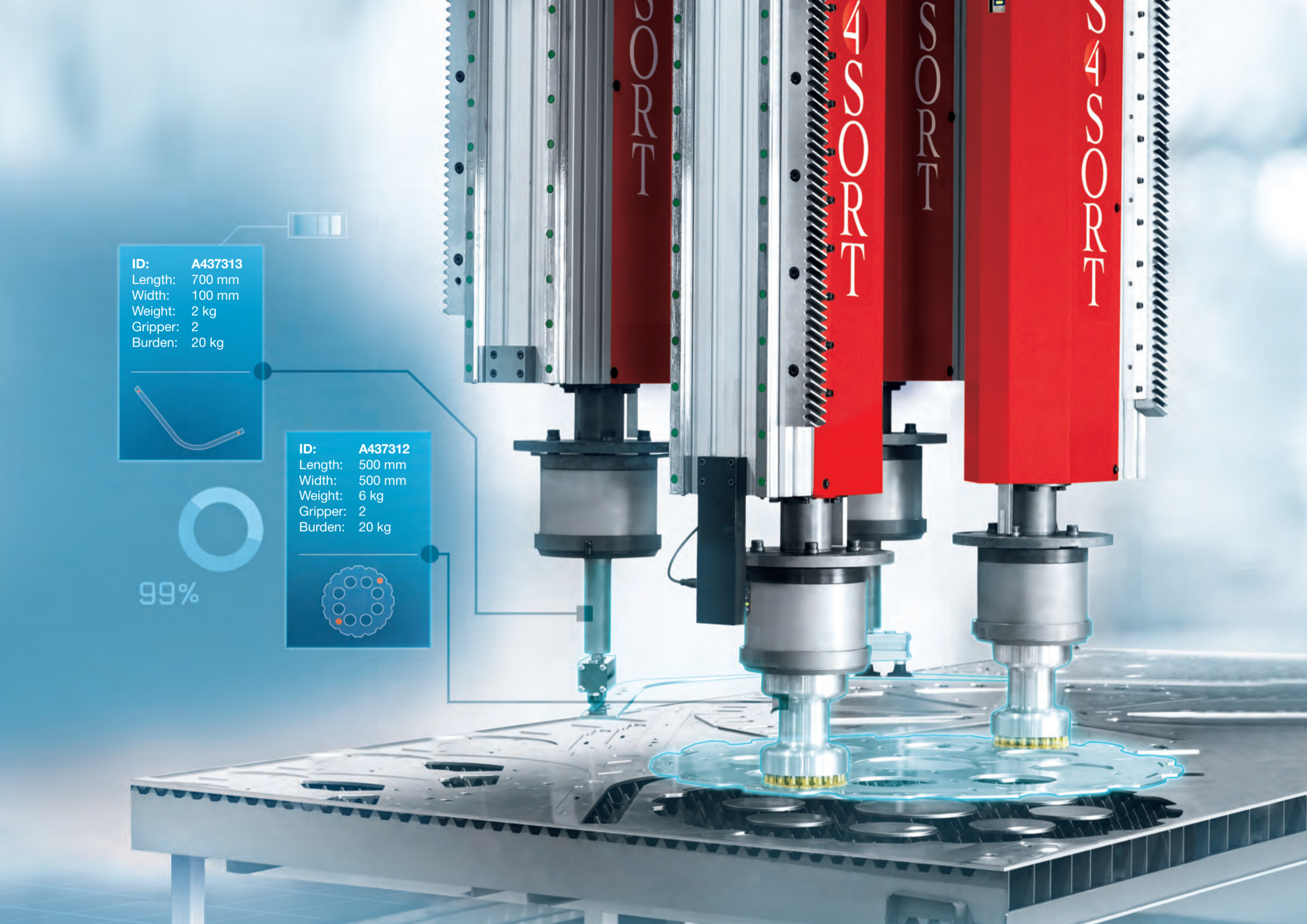

## Innovative flexibility – Flexible for today and tomorrow.

ASTES4 .....	5	Highlights .....	7
<b>Equipment and options</b>			
Automation .....	9	Tools .....	15
Efficient production cell .....	11	Operation .....	17
Pallet-ready kits .....	13		
<b>Standard production cell</b>			
Layout variants .....	21	Technical data .....	23
<b>Custom production cell</b>			
Custom .....	25	Technical data .....	27



Headquarter in Switzerland

## In the wake of the pioneer of electricity and the unit of measurement named after him.



Alessandro Volta invented the electrical battery and pioneered electricity, with the unit of measurement being named after him. Also today, forerunning inventions are being developed in the shadow of the Alps.

ASTES4 has developed and globally patented an automation system that goes a long way towards revolutionising production. To work efficiently, laser-cutting systems need a swift supply of material and subsequent sorting. ASTES4's mastery of this task is second to none, and it has now teamed up with Mitsubishi Electric for the handling of large and extra-large projects. The fact that the systems are in global demand after only a decade and, with their unique capability, often represent the only cost-effective solution shows that Volta has made a lasting mark on the region.

Explore the catalogue and pay us a visit in Switzerland.



#### Simplicity

The LASORTING system stands for simplicity. The software that controls it is designed to spare the user the complexity of the algorithms of the artificial intelligence required to perform each production order in the most efficient way.

#### Continuity

LASORTING is designed to ensure continuity through to production in terms of cutting capacity, sorting and storage. This characteristic and speed make LASORTING the ideal solution for those who want a balanced, efficient and dependable process.

#### Flexibility

LASORTING's integrated technology was developed for the handling of processes with outstanding versatility and punctuality – starting with the sheet metal parameters such as material, size and weight. The goal is to achieve the highest-possible flexibility, i.e. the shortest throughput times despite high capacity utilization. The perfect solution for those who respond fast to customer requirements – and have to produce different parts in small lots.

#### Control and intervention

The software and camera system installed in various positions in the system provide a detailed and direct overview of production as a whole so you can follow each process individually and intervene at any time by remote control.

#### Safety

LASORTING is not only the most efficient, but also the safest solution. Since parts no longer have to be detached from the skeleton and sorted by hand, this dramatically reduces the accident risk from the handling of heavy loads.

#### Customised

To meet the needs of all sectors of industry, the sorting system from ASTES4 is also available in a customer-specific version: a cell designed and built in close cooperation with the customer, with customised features and dimensions.

## Lasers are getting faster and faster and sorting is as well ... if it's from ASTES4.

### The first fully integrated system for the cutting, sorting and storage of sheet metal

LASORTING redefines the automation strategy in sheet metalworking: its holistic treatment of the process has brought forth a single integrated multifunctional system capable of controlling the entire production process from cutting and sorting through to the storage of the finished parts.

The outcome of cooperation between Mitsubishi Electric and ASTES4 – LASORTING – is the synthesis of the most advanced technologies in 2D laser cutting and flexible automation. A project inspired by the simple idea of increasing the industry's process efficiency and performance to a new level.



Now watch the film!  
[www.mitsubishi-laser.de/astes4-en](http://www.mitsubishi-laser.de/astes4-en)



Past <<< >>> Today and tomorrow

Laser-cutting system only

Manual handling of material only

Laser-cutting system with pallet changer

Manual handling  
No sorting

Laser-cutting system with loading/unloading unit

Automatic loading/unloading  
No sorting

LASORTING flexible production cell

Fully automatic process

## If you want to make money, automate!

But say goodbye to one thing: sorting errors. Now they're automatically correct!

### Quality and secure investment with Mitsubishi Electric

If you're looking for the very latest Fiber or CrossFlow laser-cutting systems and want dependability derived from 35 years of experience, you're bound to arrive at Mitsubishi Electric sooner or later. With its high vertical integration, Mitsubishi Electric produces a large proportion of its own parts itself and can therefore adapt them perfectly to requirements while also ensuring a parts supply for decades to come. The laser-cutting systems for LASORTING are designed to operate dependably, efficiently and with the highest cutting quality. They are capable of processing sheets measuring 3 x 1.5 m and 4 x 2 m in an output range of 2 to 8 kW.



### Process control

LASORTING features all the benefits of the ASTES4SORT technology developed and patented by ASTES4. All loading, unloading and sorting processes are controlled by 4 cartesian grippers. A unique system that combines exceptional versatility with remarkable execution speed and manoeuvrability. The system can be seamlessly integrated in ERP and other management systems.

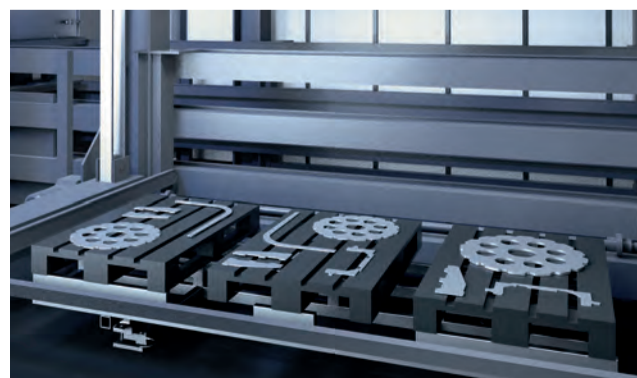

### Fully automatic warehouse

A fully automatic warehouse with a sorting system ensures optimum materials flow and continuous processes. Stocktaking at the press of a button and a complete overview of all critical process data are thus possible.

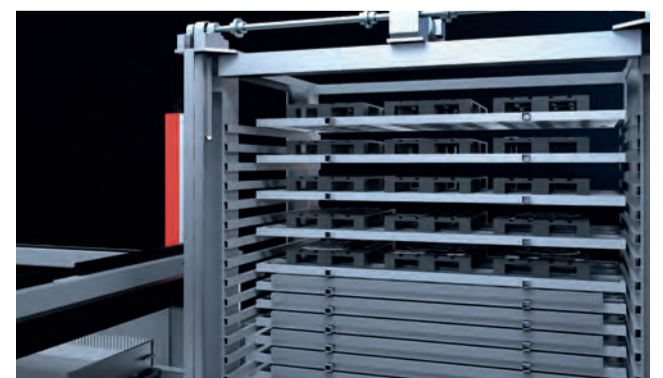



## The efficient production cell

that gives your competition sleepless nights ... and enables you to sleep soundly.

LASORTING ensures continuity of production in terms of laser workload, sorting and storage. Rapid and dependable processes help you stay competitive. With unmanned operations, LASORTING permits operation 24 hours per day, 7 days per week. The result is increased or stabilised output with lower unit wage costs. The employees, so far responsible for physically demanding sorting, can now be entrusted with value-generating activities.

Staying competitive: The orders are intelligently processed without jeopardizing efficient material utilisation – thus excluding order-picking errors and time lost between the various process steps. All this brings down the costs that would arise due to downstream manual handling.

**Loading**



**Sorting**

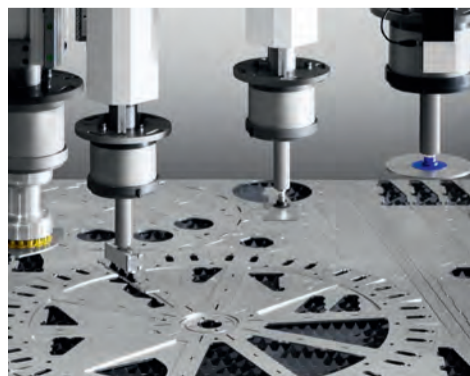

**Skeleton removal**



**Palletizing**

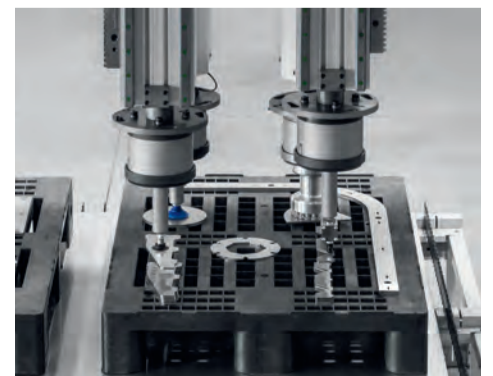

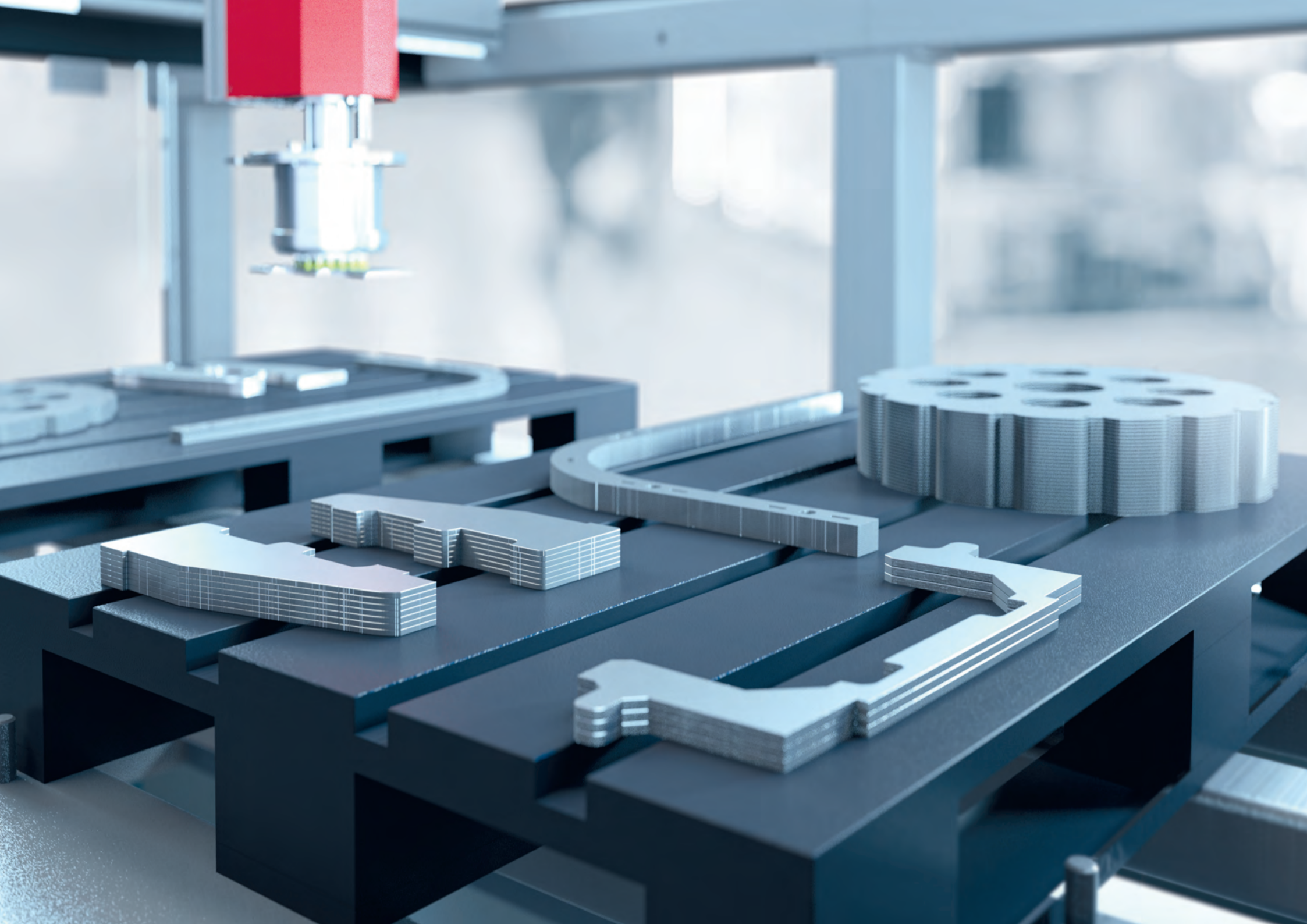

## Perfectly sorted in kits – even with different material thicknesses and labelled if desired.

Only when the downstream process steps (such as bending, welding and painting) are taken into account from the outset can work continue without lost time. ASTES4 ensures precisely this seamless integration into the production process, regardless of whether the downstream process takes place on your own site or elsewhere.

### Wide variety of sorting options

Kits of different thicknesses cut parts can be kitted on the same pallet.

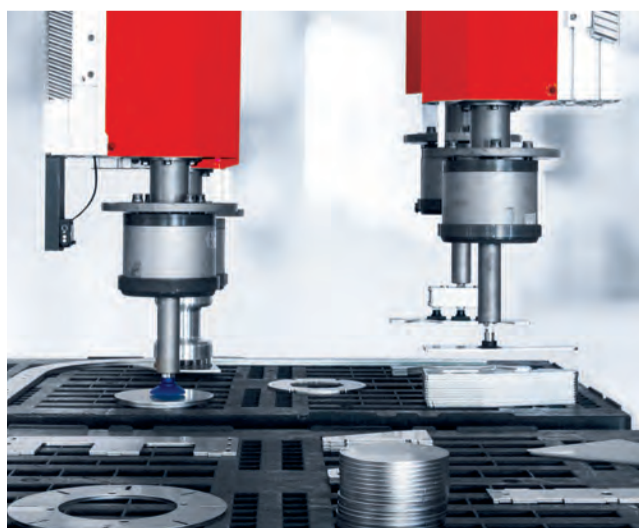

### Optional labelling machine

Enables parts to be tracked with the aid of labels.

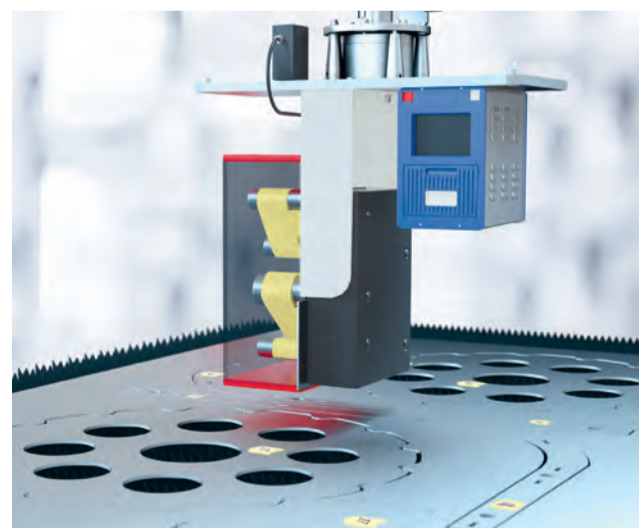

### Intelligent sorting, ready to be shipped

Production process is tailored to your needs. Either in boxes or stacked on pallets ASTES4 can do it.



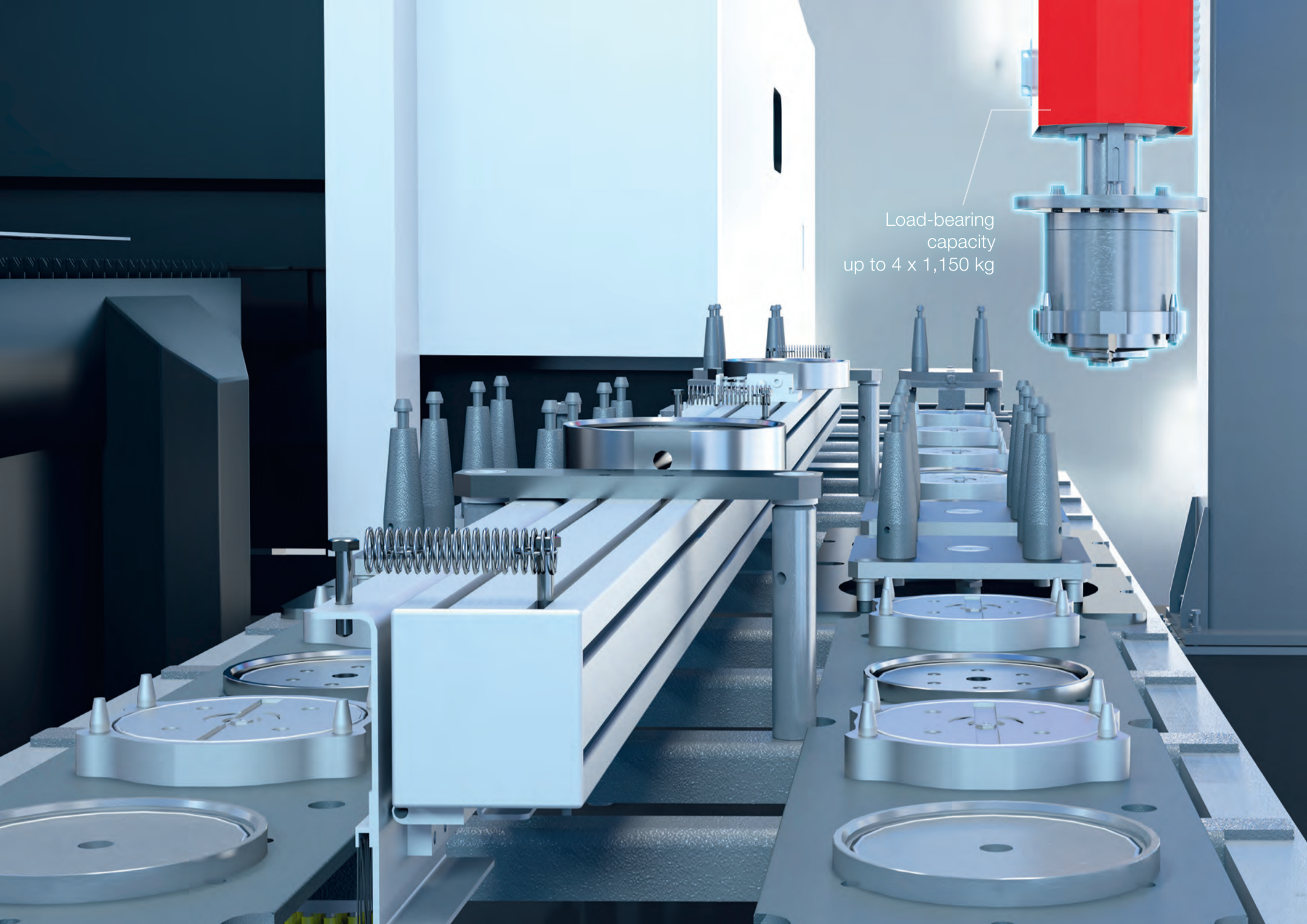

## Tool – adaptive tool change.

Four grippers are better than one or two, particularly when your laser-cutting process depends on sorting speed. This is precisely where the ASTES4 patent comes into play. Each gripper is capable of using vacuum or magnetic tools in a variety of shapes and sizes. These tools are automatically changed to suit the geometry and weight of the part. The grippers can operate individually or collectively to move large or heavy parts and are thus vastly superior to all conventional laser automation systems in terms of productivity and efficiency.

The grippers can be magnetic or pneumatic and come in a huge variety of shapes

360 degree rotation  
and +/-90 degree tilt

**+** Option







**Of course we use artificial intelligence ... for simplicity's sake.**

The software that controls it is designed to spare the user the complexity of the algorithms of the artificial intelligence required to perform each production order in the most efficient way.

## Programming in four clicks ... it couldn't be simpler. Programming? What for?

The software automatically optimises and manages the production process through to storage, without the user having to intervene. The outcome is unsurpassed user-friendliness. The user only has to select the pallets being used and everything proceeds automatically as a single production order – management of various materials, part quantities, sorting and storage – based on purchase orders and deliveries.

Simplicity also means plug & play technology. Thanks to the experience of ASTES4 and Mitsubishi Electric, the installation of the unique LASORTING system is a simple and swiftly accomplished task with the advantage of a dramatic reduction in lead time from the start of installation to the start of production.

### Three different sheet/plate thicknesses are sorted and deposited on four pallets

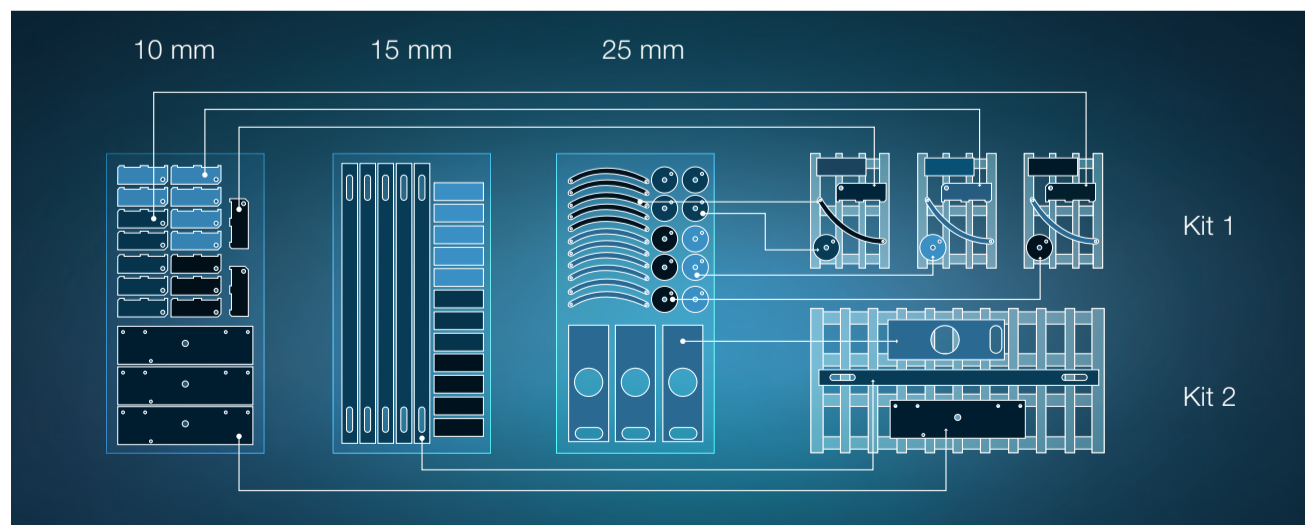

### Simply graphic operation, precise result





## Process autonomy you can take with you.

### Remote but close at hand

Remote access and the camera system installed in various positions in the system provide a detailed and direct overview of production as a whole so you can follow each process individually and intervene at any time by remote control.

Good to know that production is running while you put your feet up – 24/7 for the jobs that have been prepared accordingly. That's present-day production.



Watch it live!  
[www.mitsubishi-laser.de/remote-en](http://www.mitsubishi-laser.de/remote-en)



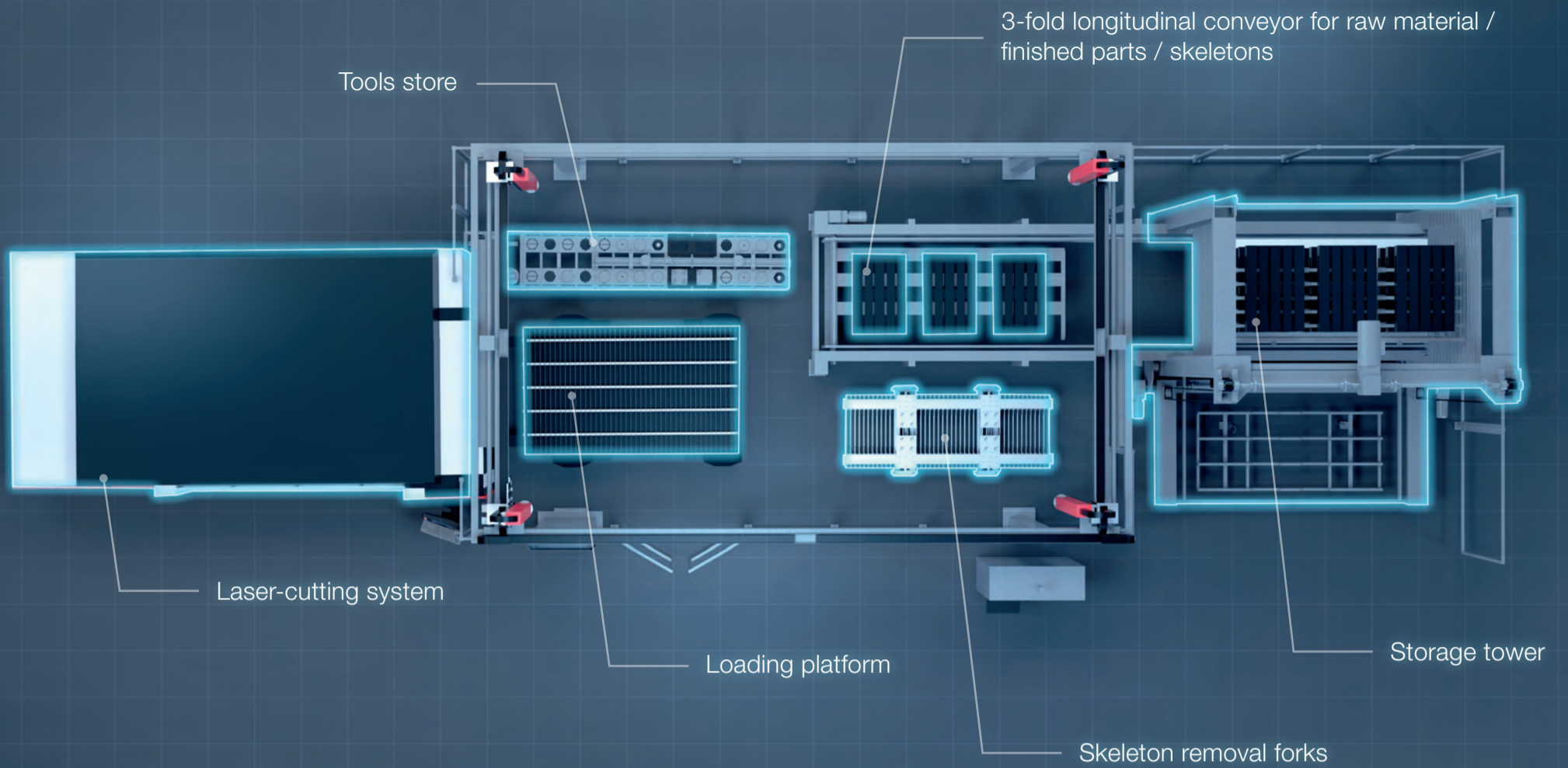

Thanks to its modularity, the LASORTING production cell adapts to the customer's production requirements and space available on site. A fully integrated production cell consisting of the laser module and sorting system with integrated storage becomes a single unit that is far more productive than the mere sum of its parts. The intelligence of this solution can be found in the software that controls the entire process, ensuring automation and flexibility at the same time – entirely in accordance with the customers' needs.

Standard production cell

## Flexible for today and tomorrow – one layout will fit!

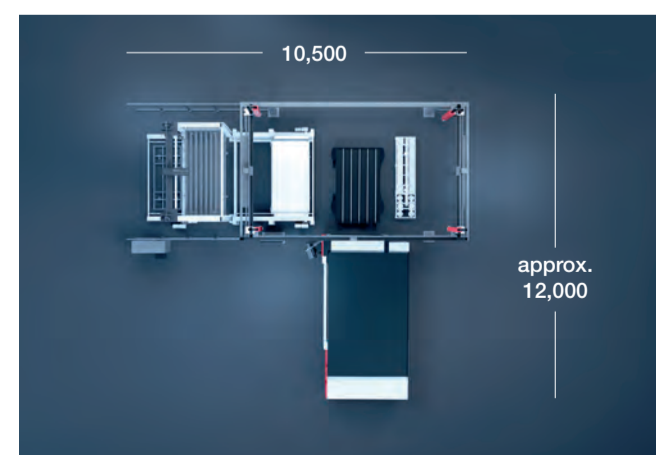
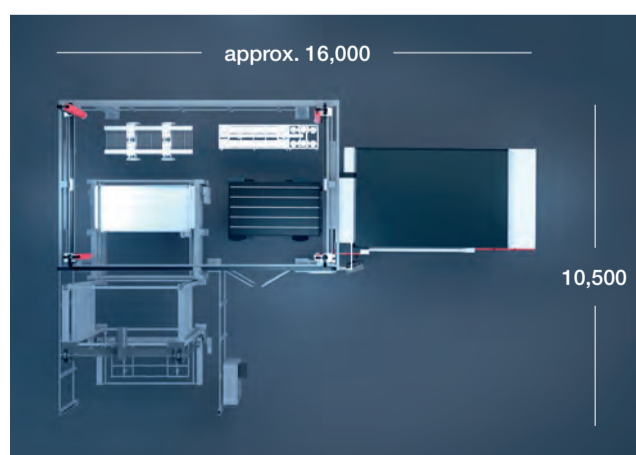
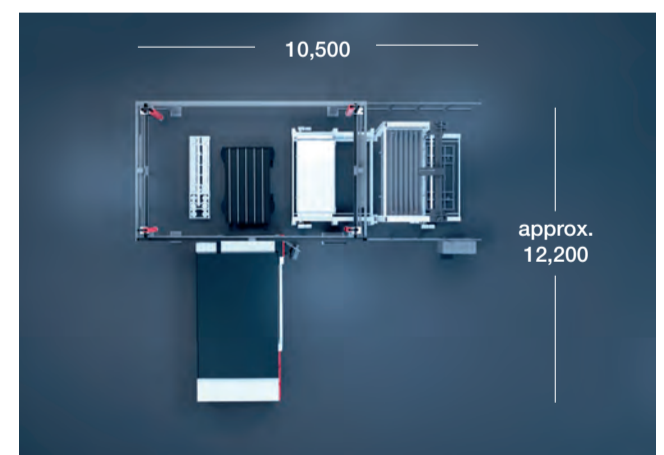
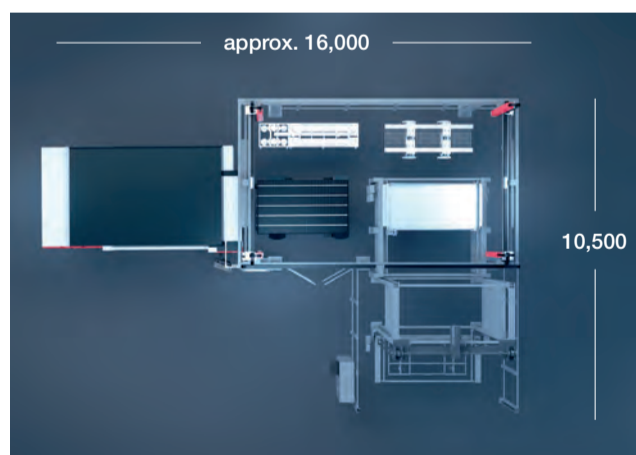
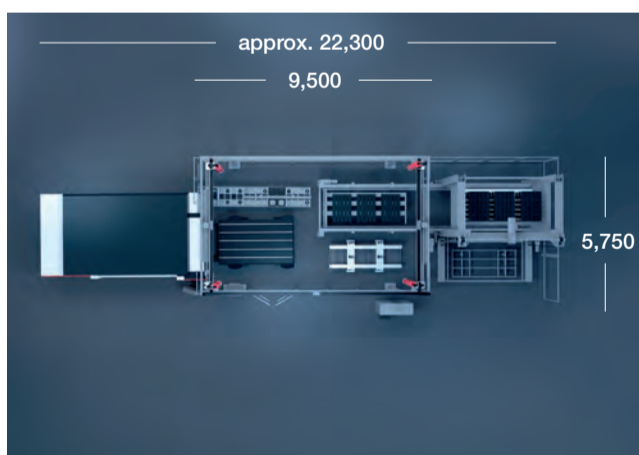

All dimensions in mm

# Standard production cell



Up to 4,000 x 2,000 mm

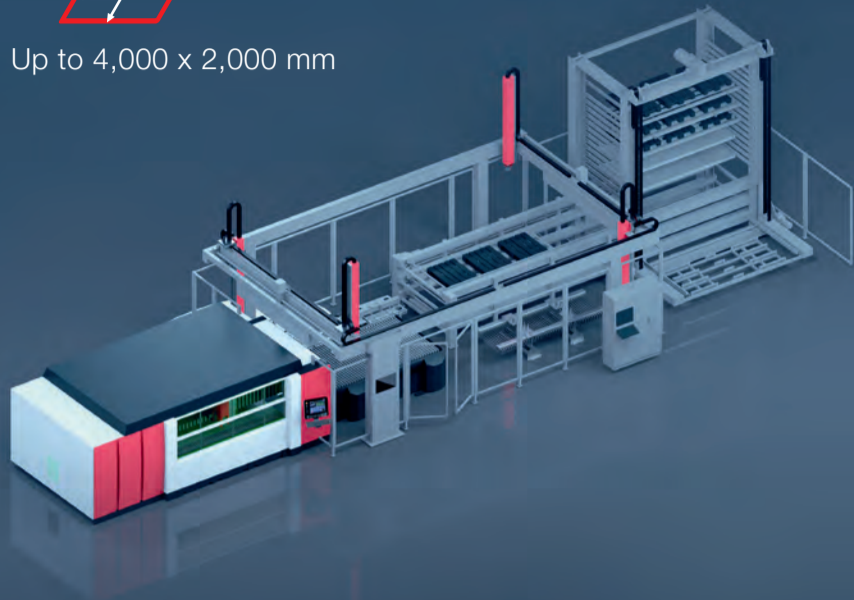

Up to 4,000 x 2,000 mm

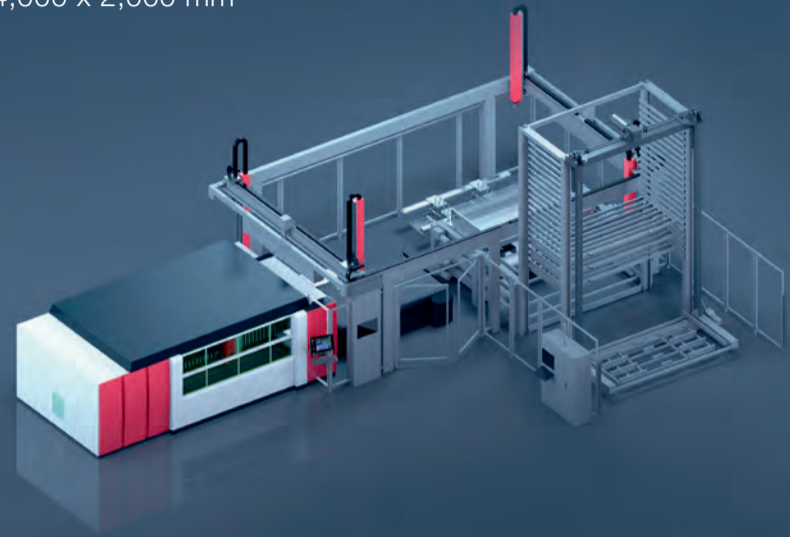

## LASORTING Light

For the machining of thin sheet

## LASORTING Sort

For the machining of thick and thin sheet

		LASORTING Light	LASORTING Sort
Sheet size		3015/4020 mm	
Sheet thickness		0,5–10 mm	0,5–25 mm
Laser technology		Fiber/CrossFlow	
Laser output		2–8 kW	
Max. sortable part size		3,000 x 1,500 / 4,000 x 2,000 mm	
Number of NC-controlled axes (sorting system)		14	16
Load-bearing capacity	Per head	250 kg	500 kg
	Total	1,000 kg	2,000 kg
Rotation	W-Axis	360°	
	J-Axis	-	
Max. speed		230 m/min [3,8 m/sec]	240 m/min [4 m/sec]
Max. acceleration		1 g	
Autonomous working Raw materials	Conveyor	5,000 kg	
	Warehouse	15,000 kg	
4-fold conveyor	Number	1	
	Number of shells	1 sheet blank pallet, 2 order-picking pallets, 1 skeleton pallet	
Warehouse	Number of towers	Single tower	
	Height	6,000–8,000 mm	
	Number of shells	5 sheet blank pallets, 4 to 9 order-picking pallets, 1 skeleton pallet	

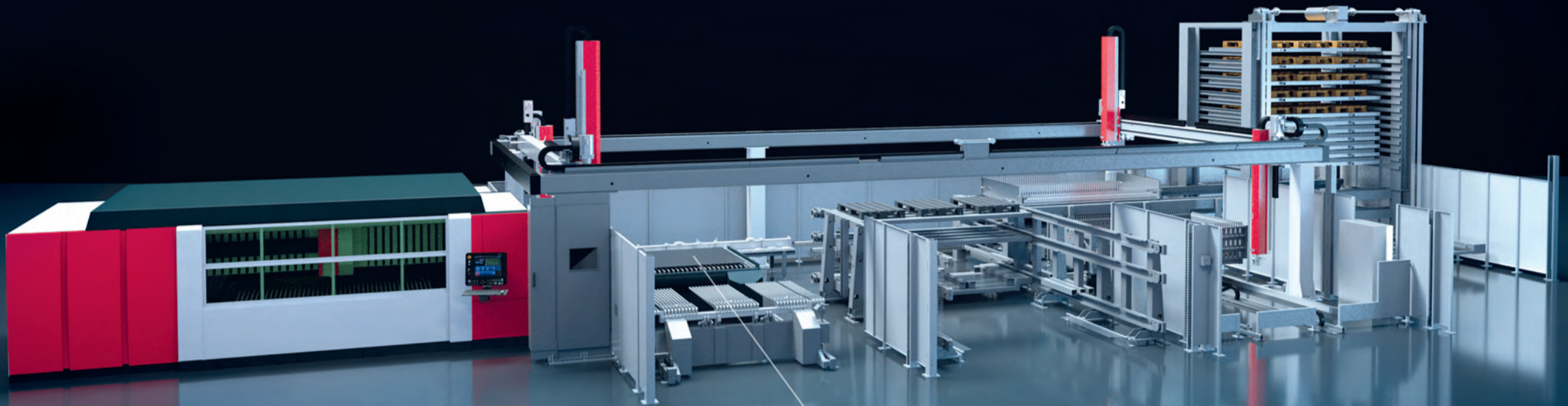

Up to 8,000 x 3,000 mm  
panel size

Custom production cell

## Meeting your requirements to perfection.

An automation solution is only ever as good as its tailoring to the needs of the customer. ASTES4 specialises in adapting to your needs – regardless of the length, width and height of the storage system. Get in touch with us and benefit from the experience that will boost your productivity – for good!

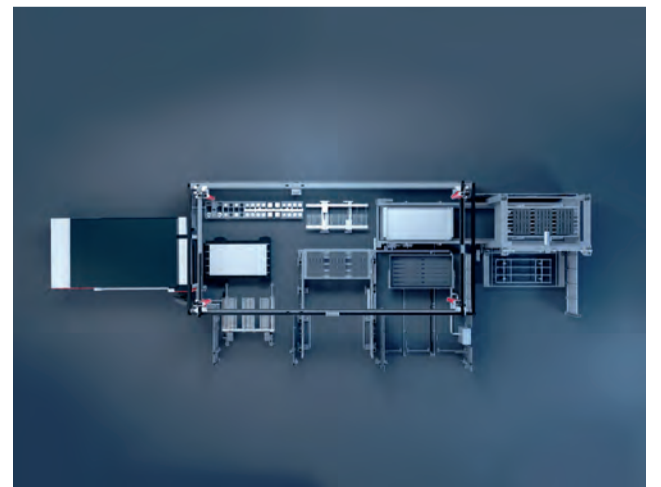
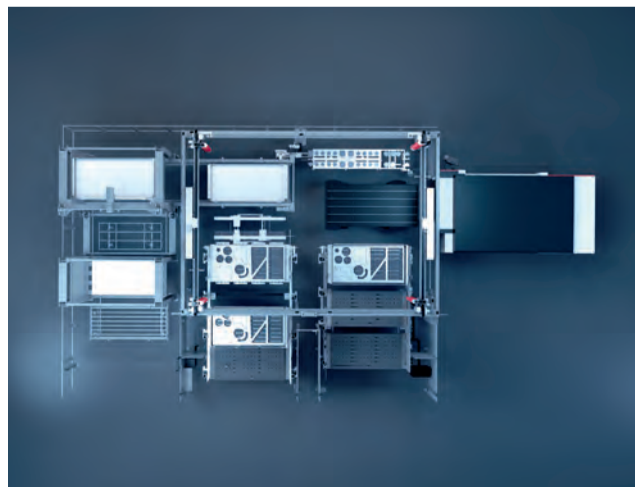
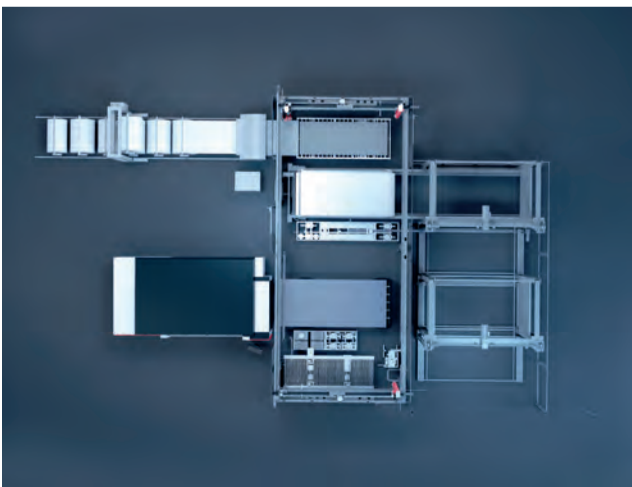

# Custom production cell



Up to 4,000 x 2,000 mm



Up to 4,000 x 2,000 mm



Up to 8,000 x 3,000 mm

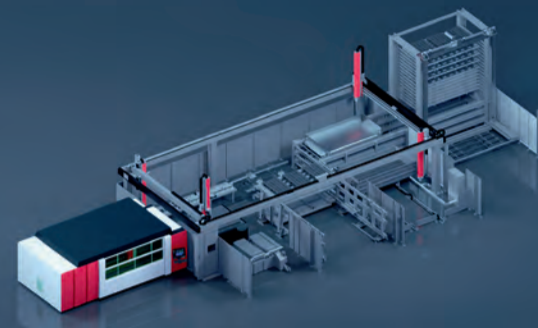
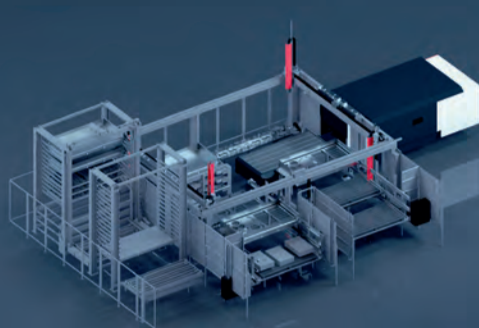
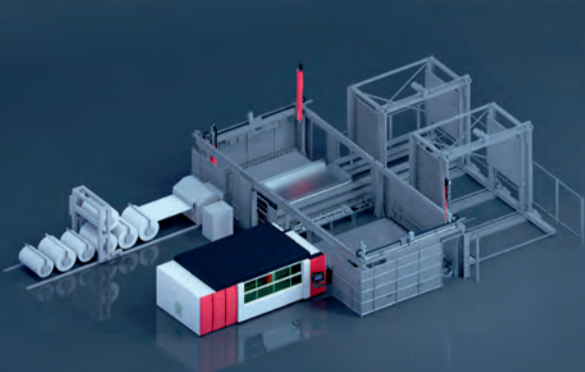

## LASORTING Light

For the machining of thin and light sheet

## LASORTING Sort

For the machining of thin and heavy sheet

## LASORTING Heavy

For the machining of large and heavy sheet

		LASORTING Light	LASORTING Sort	LASORTING Heavy
Sheet size		3015/4020 mm		6530/8030 mm
Sheet thickness		0,5–10 mm	0,5–25 mm	
Laser technology		Fiber/CrossFlow		
Laser output		2–8 kW		4–8 kW
Max. sortable part size		3,000 x 1,500 mm / 4,000 x 2,000 mm		8,000 x 3,000 mm
Number of NC-controlled axes (sorting system)		14	16	16
Load-bearing capacity	Per head	250 kg	500 kg	1.150 kg
	Total	1,000 kg	2,000 kg	4,600 kg
Rotation	W-Axis	360°		
	J-Axis	90°		
Max. speed		230 m/min [3,8 m/sec]	240 m/min [4 m/sec]	200 m/min [3,3 m/sec]
Max. acceleration		1 g		0,8 g
Autonomous working	Conveyor	5,000 kg		10,000 kg
Raw materials	Warehouse	15,000 kg		min. 25,000 kg
4-fold conveyor	Number	As required		
	Number of shells	As required		
Warehouse	Number of towers	As required		
	Height	As required		
	Number of shells	As required		

Partners

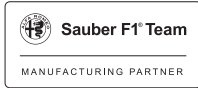

**ASTES4 SA**  
Via Passeggiata 3A / 6828 Balerna / Switzerland  
Tel. +41 91 6829320-321 / info@astes4.ch / www.astes4.ch



**MITSUBISHI ELECTRIC EUROPE B.V.**  
Mechatronics Machinery / Mitsubishi-Electric-Platz 1 / 40882 Ratingen / Germany  
Tel. +49 (0) 2102 486-0 / laser.sales@mee.com / www.mitsubishi-laser.de